

Care and Safety

- Periodically check all fittings to ensure that none have come loose.
- The desk must be set up on an even and stable surface.
- Clean your desk by wiping with a damp cloth & drying with a soft cloth.
- Never clean with abrasives, chemical cleaners or household polishes.
- Keep away from direct sources of heat, such as electric, gas or coal fires.
- Take care when handling or moving the desk. Careless handling can damage wooden furniture.
- Climbing on, or using this desk other than for its intended purpose, could cause damage to the structure or serious injury to your child.

If you have a problem with this product, or require replacement parts, call ASPACE Ltd. on

0845 872 2400

ASPACE

REAL FURNITURE - FOR KIDS

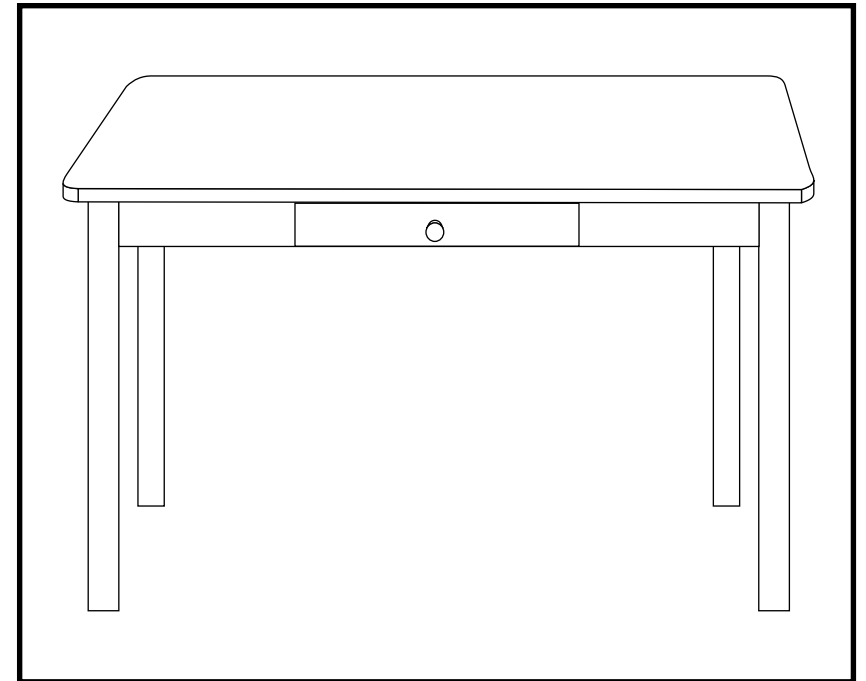

Writing Table

7075 / 7076 / 7125

PLEASE READ CAREFULLY & KEEP FOR FUTURE REFERENCE

Checklist

Please note: the components will vary in design, depending on the product

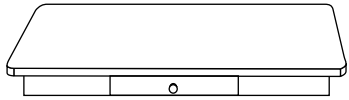

1 Desktop

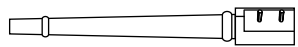

4 Legs



8 Nuts



8 Washers

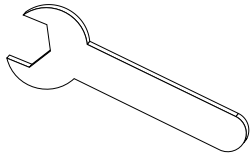

You will need a suitable spanner or adjustable wrench.

Putting the Desk Together

1. Remove the drawer.

Lay the Desktop, top down, on a soft clean flat surface, (such as a carpeted floor).

Bring the legs up to the metal corner brackets, allowing the integral bolts to penetrate the holes.

Place a washer over each bolt and secure tightly with the nuts.

With help, raise the desk upright, place in position and replace the drawer.

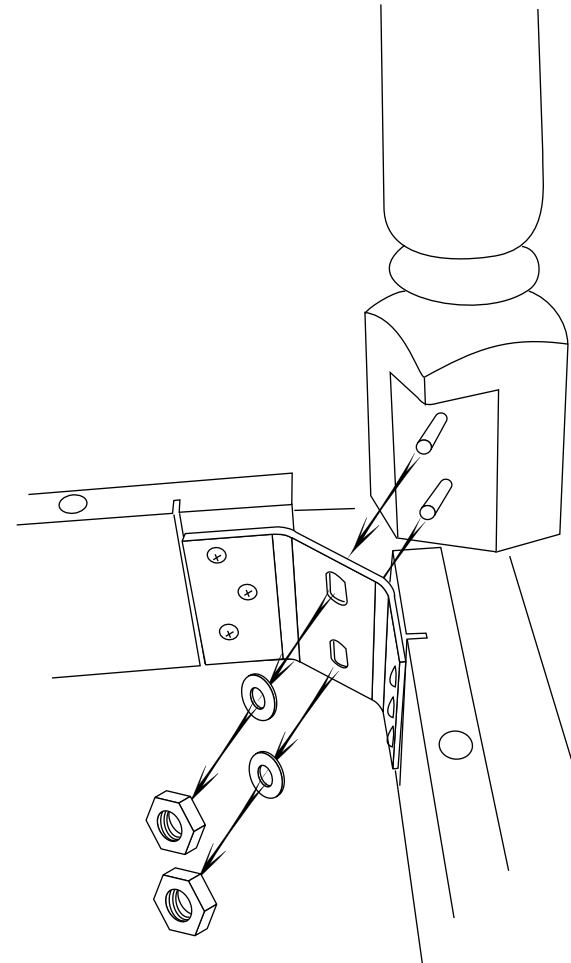

THIS IS A HEAVY PIECE OF FURNITURE: TO AVOID UNDUE STRESS AND DAMAGE TO THE JOINTS, (AND TO YOURSELF), WE STRONGLY ADVISE ALWAYS USING TWO PEOPLE TO LIFT IT.